

DF 30

Semi-Automatic Bottom Seal Strapping Machine

An economical, easy to use strapping machine designed to run 1/4" - 5/8" strapping.

Equipped with externally adjustable strap feed and electronic tension control, the DF-30 is the perfect machine for securing and unitizing outgoing shipments of mail trays or bundled mail. Offering added safety for the operator the DF30 has been redesigned with rounded corners, as well as an audible cycle alert safety signal. An "ACASS" is given when the strap has been inserted into the sealing mechanism prior to tensioning.



Features

- Utilizes a direct drive dual motor system, eliminating the need for clutches and brakes
- Improved strap feed system eliminates slipping during tensioning even under the harshest conditions
- Suited to handle all office and industrial packaging applications
- New, state-of-the-art innovative design with rounded corners for personal protection
- Compact, lightweight assembly, for easy mobility throughout your facility
- Compact, low maintenance sealer head
- 5mm - 15mm strapping can be used
- Audible cycle alert safety signal (ACASS) system
- Cycle time capable of 25 - 30 straps per minute
- Strap feed and tension are externally controlled
- Minimal maintenance and lubrication required
- Easily accessible strap dispenser
- Dispenser braking system with no belts to wear or adjust
- Complete accessibility for maintenance
- Operates on 120 volt single phase power



5740 Bayside Road, Virginia Beach, VA 23455

Phone: (800) 526-0827 Fax: (757) 363-8016

E-mail: gd@dynaric.com

Web address: www.dynaric.com

DF 30

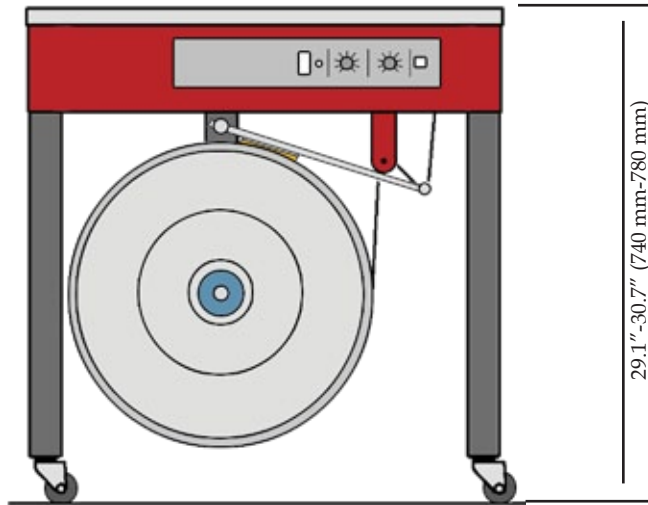

Front View

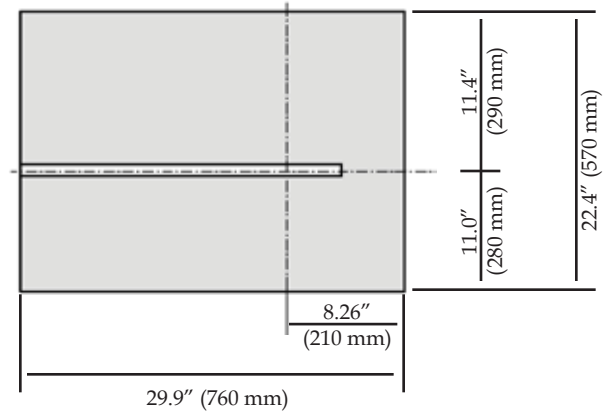

Top View

Technical Specifications

Overall Width:	22.4" (570 mm)
Overall Length:	29.2" (760 mm)
Overall Height:	29.1"-30.7" (740 mm-780 mm)
Machine Weight:	149.9 lbs. (68 kg.)
Sealing Method:	Heat Seal
Sealing Head Location:	11.0" (280 mm) from the right of the machine
Power Supply:	120V Single Phase
Cycle Time:	2.0 Seconds*
Cycle Initiation:	Strap Insertion with "ACASS" System

Tension:	External Electronically Adjustable
Min. Package Size:	4" (102 mm)H x 2.4" (61 mm) W
Max. Package Weight:	180 lbs. (81.6 kg)
Mobility:	4 Casters, two are locking
Strapping Size:	1/4" (5 mm) - 5/8" (15.5 mm)
Dispenser:	9" (229 mm) I.D./8" (203 mm) face/18" (457 mm) O.D. 8" (203 mm) I.D./8" (203 mm) face/18" (457 mm) O.D.

* Based on Package Size



5740 Bayside Road, Virginia Beach, VA 23455

Phone: (800) 526-0827 Fax: (757) 363-8016

E-mail: gd@dynaric.com

Web address: www.dynaric.com